

Quest 335

Installation, Operation and Maintenance Instructions

– Read and Save These Instructions –

This manual is provided to acquaint you with the dehumidifier so that installation, operation and maintenance can proceed successfully. Ultimate satisfaction depends on the quality of installation and a thorough understanding of this equipment. The dehumidifier is built around tested engineering principles and has passed a thorough inspection for quality of workmanship and function.



Patent: thermastor.com/patents

Features:

- 208V and 230V 60Hz
- Industry-leading efficiency
- Patented, multi-coil refrigeration system
- High-efficiency, variable-speed impeller
- Quiet operation
- Superior air filtration (MERV-13 standard)
- Auto-restart after loss of power
- Environmentally friendly R410A refrigerant
- Low voltage external control
- On-Board digital controls

Water Removal Rates (Pints/Day) @ 80°F 60% (RH)

Dehumidifier	Pints Removed	Gallons/Liters
335	335	42/158



4201 Lien Rd
Madison, WI 53704
www.QuestClimate.com

Toll-Free 1-877-420-1330
info@QuestClimate.com

Table of Contents

Safety Precautions 3

1. Intended Application 4

2. Registrations 4

3. Specifications 4

4. Installation 5

 4.1 Location 5

 4.2 Electrical Requirements..... 5

 4.3 Condensate Water Removal..... 6

 4.4 Hanging Diagram 7

 4.5 Hard-Wiring Instructions..... 8

 4.6 Supply & Return Duct Kit11

5. Control Options.....12

 5.1A On Board Dehumidistat.....12

 5.1B External Control Options.....13

 5.2 External Control 14

6. Maintenance 14

 6.1 Standard Air Filter..... 14

 6.2 Impeller Fan Oiling..... 14

7. Service15

 7.1 Warranty15

 7.2 Technical description.....15

 7.3 Troubleshooting.....15

 7.4 Refrigerant Charging 17

 7.5 Impeller Fan Replacement 17

 7.6 Compressor/Capacitor Replacement 17

 7.6A Checking Compressor Motor Circuits 17

 7.6B Replacing Burned Out Compressor18

 7.6C Replacing Compressor-Nonburn Out19

 7.7 Remote Controls.....19

 7.7A Humidity Control.....19

 7.8 Defrost Thermostat.....19

 7.9 Condensate Pump Kit19

8. Error Codes 20

Wiring Diagram21

Service Parts List22

Optional Parts List22

Warranty24

Safety Precautions

Read the installation, operation and maintenance instructions carefully before installing and operating this device. Proper adherence to these instructions is essential to obtain maximum benefit from your **Quest** Dehumidifier.

READ AND SAVE THESE INSTRUCTIONS

- The device is designed to be installed **INDOORS IN A SPACE THAT IS PROTECTED FROM RAIN AND FLOODING.**
- Install the unit with space to access the back or side panels for maintenance and service. **DO NOT INSTALL UNIT WITH THE SERVICE PANELS INACCESSIBLE.**
- Avoid directing the discharge air at people, or over the water in pool areas.
- If used near a pool, spa or water; be certain there is **NO** chance the unit could fall into the water, be splashed and that it is plugged into an outlet that is a **GROUND FAULT INTERRUPT** protected circuit.
- **DO NOT** use the device as a bench or table.
- **DO NOT** place the device directly on structural members. Provide vibration isolation in order to minimize operational vibration and/or noise.
- A drain pan **MUST** be placed under the unit if installed above a living area or above an area where water leakage could cause damage
- Never operate a unit with a damaged power cord. If the power cord is damaged it must be replaced by the manufacturer, its service agent, or similarly qualified person in order to avoid a hazard.
- Make all electrical connections in accordance with the current edition of the NEC ANSI/NFPA 70 and any national and local codes or ordinances that may apply.
- Maintain a minimum 1ft. (.3m) clearance to avoid obstructing the air return and supply.
- This appliance is not intended for use by persons (including children) with reduced physical, sensory or mental capabilities, or lack of experience and knowledge, unless they have been given supervision or instruction concerning use of the appliance by a person responsible for their safety. Children should be supervised to ensure that they do not play with the appliance.
- Not intended for use at altitudes over 2000M

1. Intended Application for Quest Dehumidifier

The Quest 335 Dehumidifier is designed to operate in temperatures between 56° and 95°F.

In order to efficiently control humidity levels, the area in which the dehumidifier is to be operated must be free of water intrusion or excessive fresh (outside) air infiltration. Before installing the Quest 335 Dehumidifier, water intrusion and air infiltration problems should be addressed or noted in calculations.

2. Registrations

The Quest 335 Dehumidifier units conform to unified standard UL 60335-2-40, CSA C22,2#60335-2-40.
 US Patents: D570,988 / 8,069,681 / 9,052,132

3. Specifications @ 80°F/60% RH

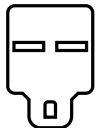
Unit:	4042500 Quest 335
Blower: (Tested with duct collars on)	1000 CFM @ 0.0" WG 1000 CFM @ 0.2" WG 1000 CFM @ 0.4" WG
Power (Watts):	1565
Supply voltage:	208V and 230V - 1 Phase - 60 Hz.
Current Draw (Amps):	6.9A @ 230V 7.9A @ 208V
Energy Factor: (L/kWh)	4.4
Operating Temp:	56°F - 95°F
Water Removal (Pints/Day): Efficiency (Pints/kWh):	335 9.3
Air Filter (MERV-11 Nominal):	Size: 22" x 20" x 2"
Power Cord: 10' 14/3 SJTW	NEMA 6-15P 
Drain Connection:	3/4" Threaded NPT
Refrigerant Type: Refrigerant Amount:	R410A 4lb. 12oz.
Dimensions:	Unit Shipping
Width:	32.88" 36"
Height:	24.38" 30"
Length:	23.5" 28"
Weight:	215 lbs 255 lbs

4. Installation

4.1 Location

The Quest 335 Dehumidifier can be installed in a variety of locations to meet the owner's needs as listed below. In all cases keep the following cautions in mind:

- Place the Quest 335 Dehumidifier on supports that raise the base of the unit 6" above the secondary drain pan so a P-trap can be installed. See Section 4.3.
- The Quest 335 Dehumidifier may be suspended with steel hanger, straps, or a suitable alternative from structural members, unit must be supported from underneath. Don't hang from sides or ends. See section 4.4
- If installing on ground, use included plugs to cover hanging locations on top of the machine.
- If hanging machine in air, use included plugs to cover holes in base pan for leveling feet.

4.2 Electrical Requirements

The Quest 335 Dehumidifier plugs into NEMA rated receptacles. The amp draws for each unit under normal operating conditions are listed on page 4. A ground fault interrupter protected circuit is required.

Install the remote hygrometer in a central area of the structure where it will sense the relative humidity of the structure accurately. Do not install the hygrometer where it may not accurately sense the relative humidity such as near HVAC supply registers, near exterior doors, or near a pool or spa. The installer must supply the wiring between the Quest 335 Dehumidifier and the hygrometer. Be sure to safely route the control wiring to prevent damage during installation. Be careful not to cross the wires when connecting the Quest 335 Dehumidifier and the remote hygrometer.

The remote controls of the Quest 335 Dehumidifier are powered by a low voltage circuit (24 VAC) and must NEVER contact or be connected to a high voltage circuit. The control terminals and remote control are labeled and numbered to prevent confusion. Be sure to consult the electrical schematic in this manual or inside the access panel of the Quest 335 Dehumidifier before making the control connections.

⚠ CAUTION! Always disconnect the Quest 335 from a power source when working with the low voltage control wires.

⚠ CAUTION! For proper drainage, the unit must be mounted so the drain outlet is at least 4” above the floor drain, and must be fully supported under the base.

4.3 Condensate Water Removal

Condensate drains by gravity via the drain port. Use 3/4” male NPT PVC pipe. An optional condensate pump kit may be installed if a lift is required to dispose of the condensate. Optional parts list for information on the kit.

Follow Diagram:

Quest 335

H = 4”

J = 2”

L = 6.75”

Vent:

- Place vent after the trap.
- Vent should be open.
- Height of vent should be higher than drain outlet.

Cap:

- A clean out can be placed before trap but must be sealed with a cap.

Drain Line:

- Drain line should go in a downward slope to the drain.
- 1/4” drop per foot.

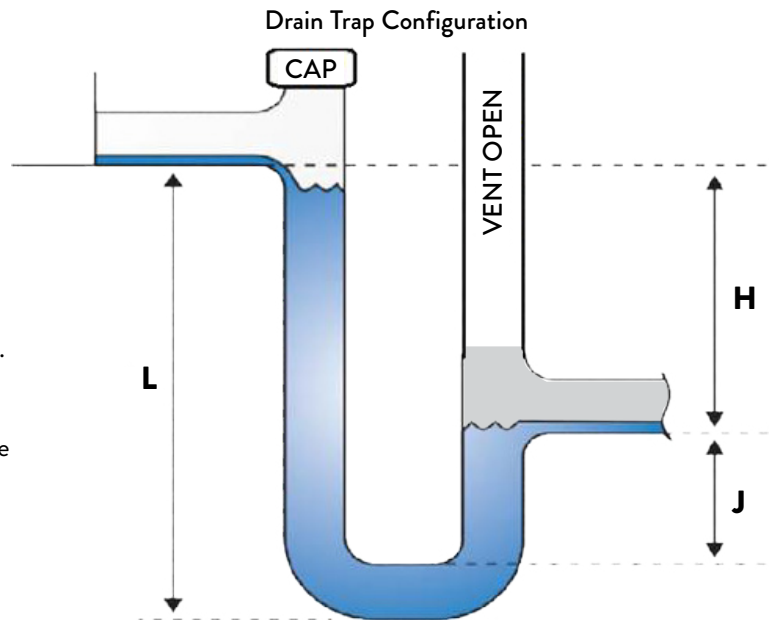

4.4 Hanging Diagram

Quest 335

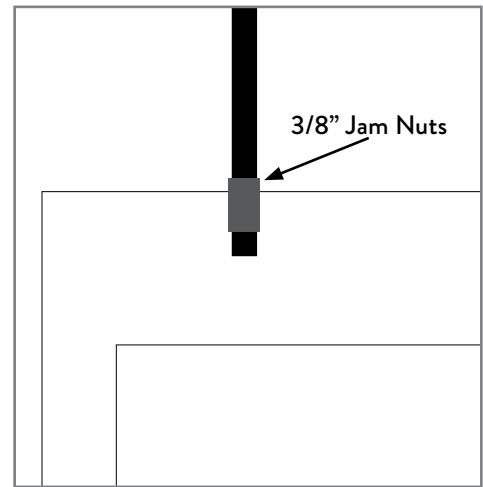
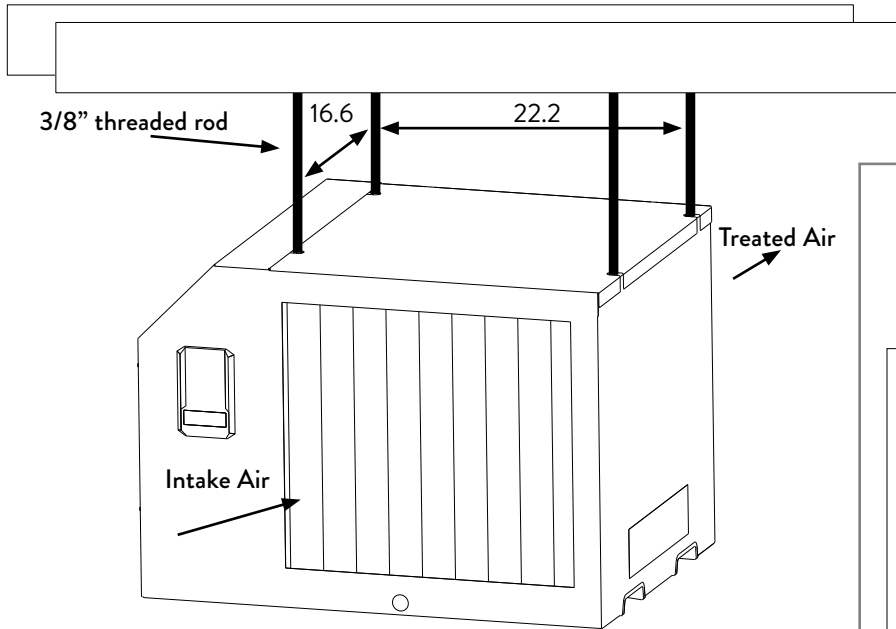

- Parts Needed:** 4 pieces 3/8" threaded rod (not included)
4 - 3/8" threaded jam nuts (not included)

⚠ Threaded rods should be engaged no less than 2" into machine.

4.5 Hard-Wiring Instructions

⚠ WARNING! SERVICING THE QUEST 335 DEHUMIDIFIER, WITH ITS HIGH PRESSURE REFRIGERANT SYSTEM AND HIGH VOLTAGE CIRCUITRY PRESENTS A HEALTH HAZARD WHICH COULD RESULT IN DEATH, SERIOUS BODILY INJURY, AND/OR PROPERTY DAMAGE. ONLY QUALIFIED SERVICE PEOPLE SHOULD SERVICE THIS UNIT.

Tools Required

- T25 Torx Driver
- 11/32" Driver

Following all local and national electrical codes and standards, route electrical service to the location that the dehumidifier will be installed.

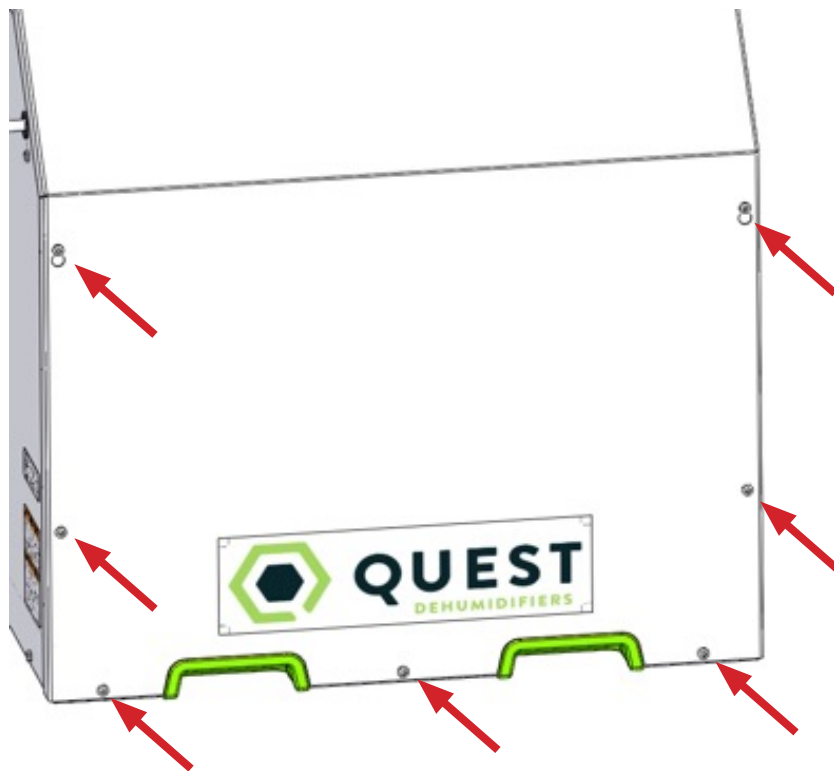

Remove 7 screws on access panel using T25 Torx driver, remove panel.

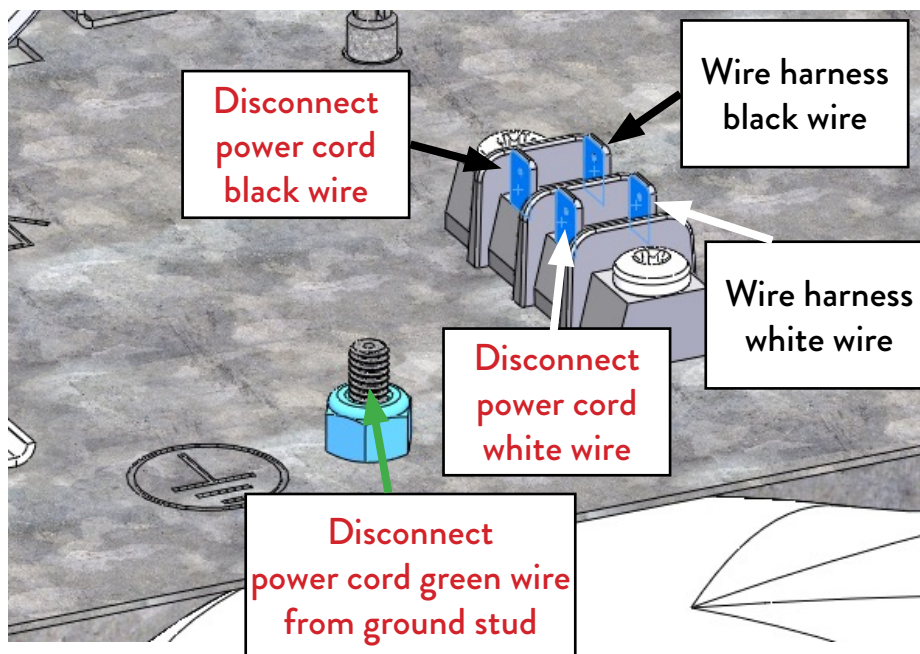

Disconnect POWER CORD BLACK wire from terminal

Disconnect POWER CORD WHITE wire from terminal.

Use 11/32" driver to remove nut from ground stud and disconnect POWER CORD GREEN wire from ground stud.

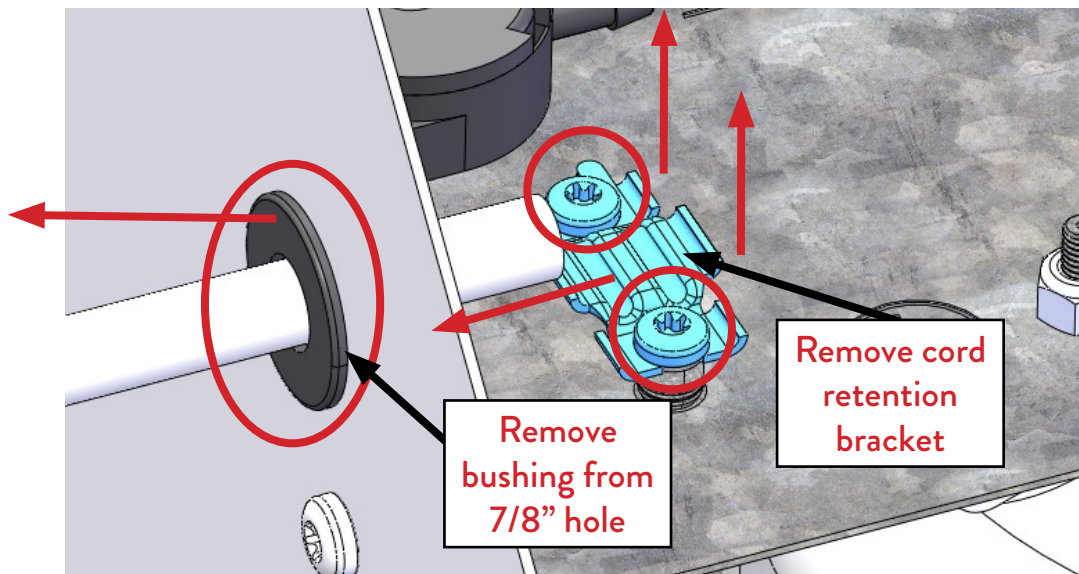

Remove the 2 screws holding the cord retention bracket using T25 Torx driver and remove retention bracket.

Remove power cord and black bushing.

Route incoming power service wires through 7/8" hole and secure using clamps intended for the conduit or cable used.

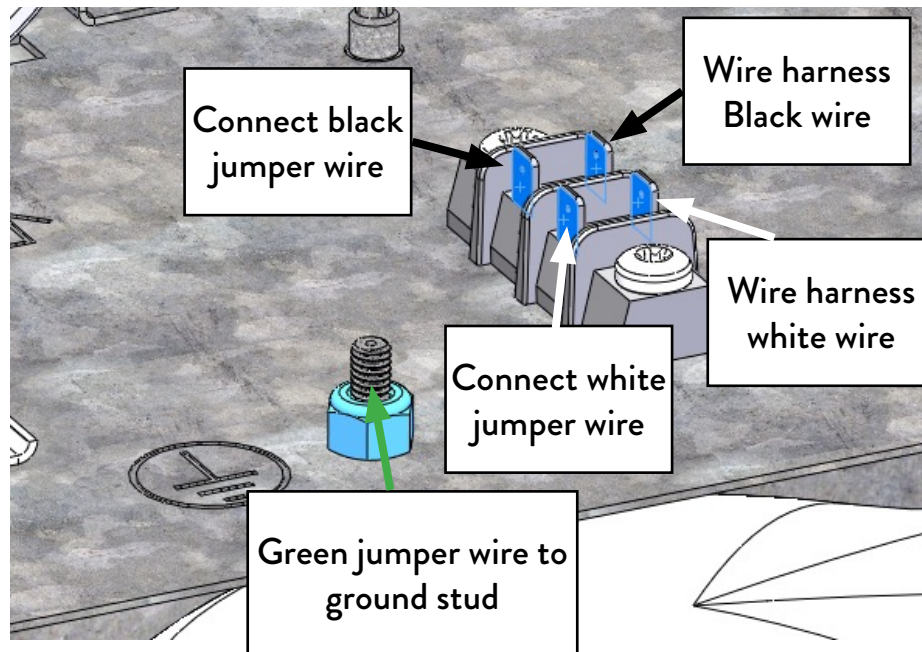

Connect BLACK and WHITE jumper wires to terminal block as shown.

Place GREEN jumper wire ring terminal on ground stud and use 11/32" driver to secure nut to stud.

Attach incoming service LINE 1 wire to BLACK jumper wire with the provided wrenut.

Attach incoming service LINE 2 wire to WHITE jumper wire with the provided wrenut.

Attach incoming service GROUND wire to GREEN jumper wire with the provided wrenut.

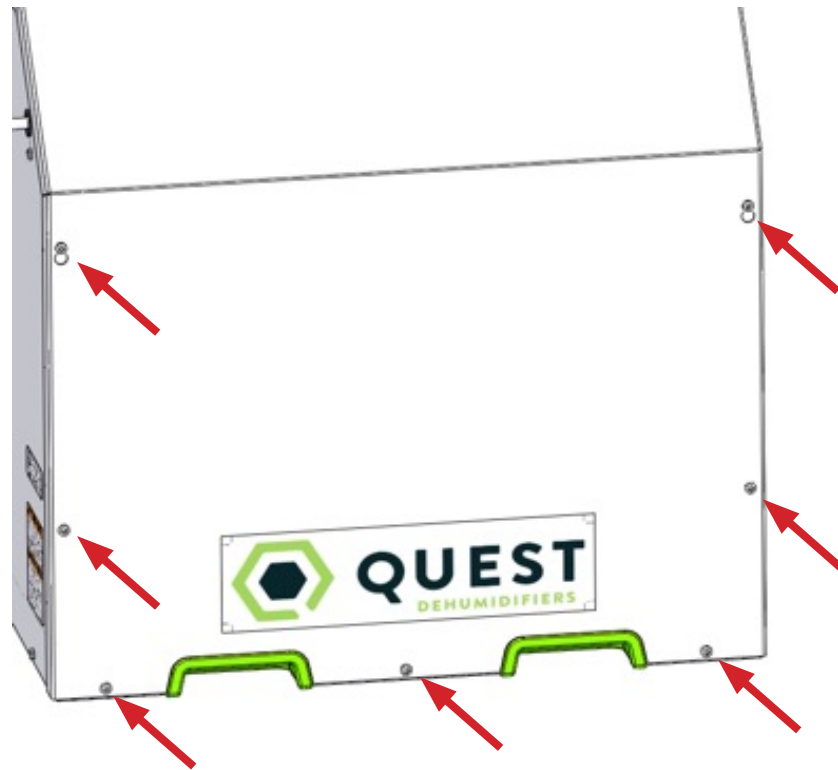

Replace access panel using T25 Torx driver to secure 7 screws.

4.6 Quest 335 Supply and Return Duct Kit (P/N 4042685)

If factory duct kit accessory was purchased, follow instructions included with duct kit.

If owner chooses to have a licensed HVAC contractor fabricate a duct kit, please follow the drawing below for safe zones for self tapping screws.

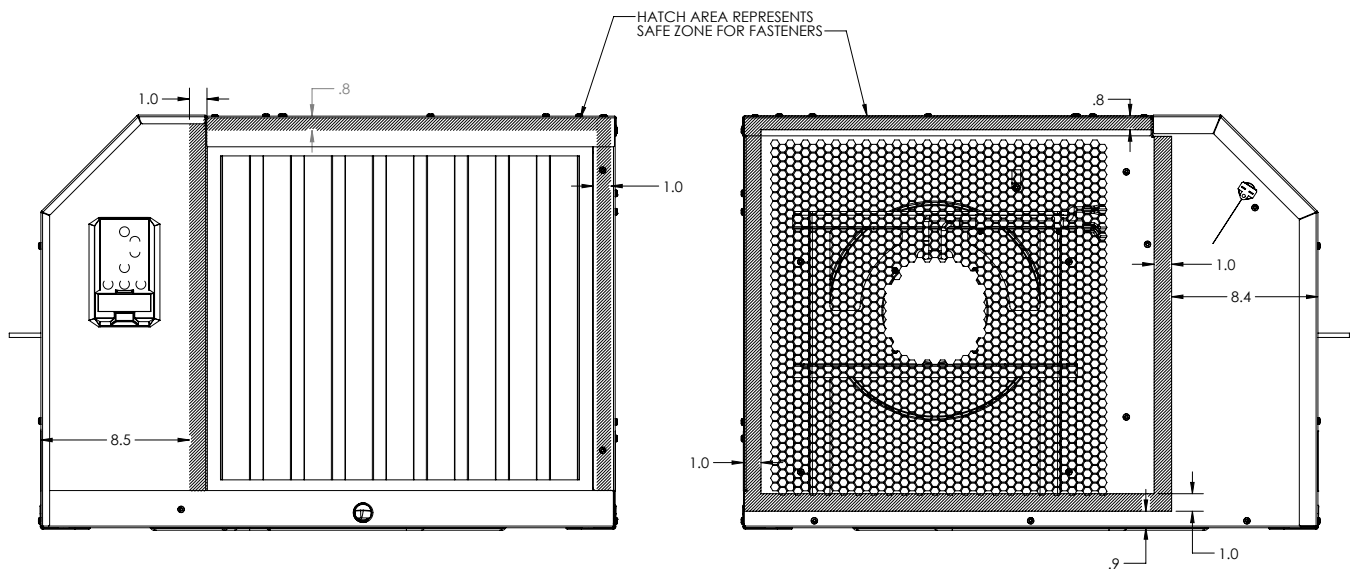

5. Control Options

The Quest 335 Dehumidifier can be controlled by its on board dehumidistat or with an external control using its low voltage terminal block.

5.1A Quest 335 On Board Dehumidistat

Off Mode: Fan, Compressor, Display and all LEDs are off

To Turn Unit On: Press the power button

On Mode: Display is on and shows the set point (Initial set point: 55% RH)

To Change Set Point:

- Press the up or down arrow once, the 2-digit display will begin to blink.
- Adjust to desired RH. Each push of the button will change the SP 1% RH.
- After 6 seconds without a button being pushed the number showing will become the new SP

Defrost Light



- The light over the snowflake will light up when defrost is occurring (ice is detected on coils). The fan will be on, and the compressor will be off during defrost.

Filter Reset



- Filter reset button will light up after the fan has been running for 2,000 hours, or if the pressure switch detects excessive pressure build-up indicating that the filter must be changed.
- After changing the filter, press and hold the filter reset button to reset the 2,000-hour timer. Light flashes while button is held.

Dark Mode



- Press the Dark Mode button to activate Dark Mode.
- Once Dark Mode is activated, lights will remain on for 20 seconds before the unit's hygrostat will go dark. Dark Mode light will flash for 3 seconds before unit goes dark.
- Unit will temporarily leave dark mode when any button is pushed and will go dark 20 seconds after the last button is pushed.
- To turn off Dark Mode, press the Dark Mode button and ensure light above Dark Mode button is off.
- This mode is for applications where the user would like the unit to operate without emitting any light.

Fan

Pressing the Fan button alternates the unit between 3 fan speeds:

- (Hi)gh: Increased fan speed to be used exclusively in ducted applications. Deactivates filter-life compensation mode.
- (Au)to: Default fan speed. Filter-life compensation mode active.
- (Lo)w: Decreased fan speed that lowers the volume and performance of the unit. Deactivates filter-life compensation mode.

Filter-life compensation mode measures the static pressure increase due to the filter particulate build-up and increases fan speed to maintain optimum airflow and performance.

Terminal Control

- When the Terminal Control button is pressed, the display will show “tc”.
- The Terminal Control button is used to activate the “DEHUM” input on the terminal block. (see section 5.1B)
- This must be activated when an external control is used to control RH. When Terminal Control is active, the internal RH sensor is disabled.

5.1B Quest 335 External Control Options

Quest offers two external control options

4028531

QUEST DEH 3000R CONTROL WIRING DIAGRAM

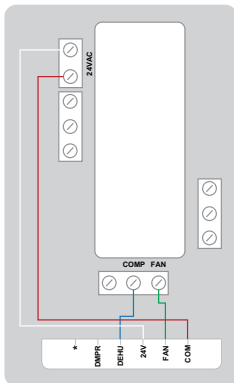

DEH 3000R

NOTE: 22 ga wire needed for sensor

Contact your dealer or call 1-877-420-1330 to order or go to www.questclimate.com/product-category/accessories.

4020175

HONEYWELL REMOTE HUMIDISTAT WIRING DIAGRAM

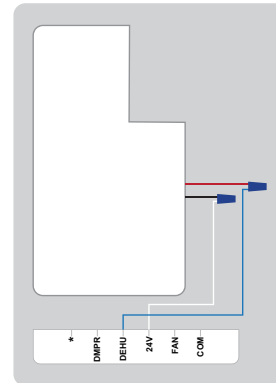

Honeywell Remote Humidistat

Daisy Chain

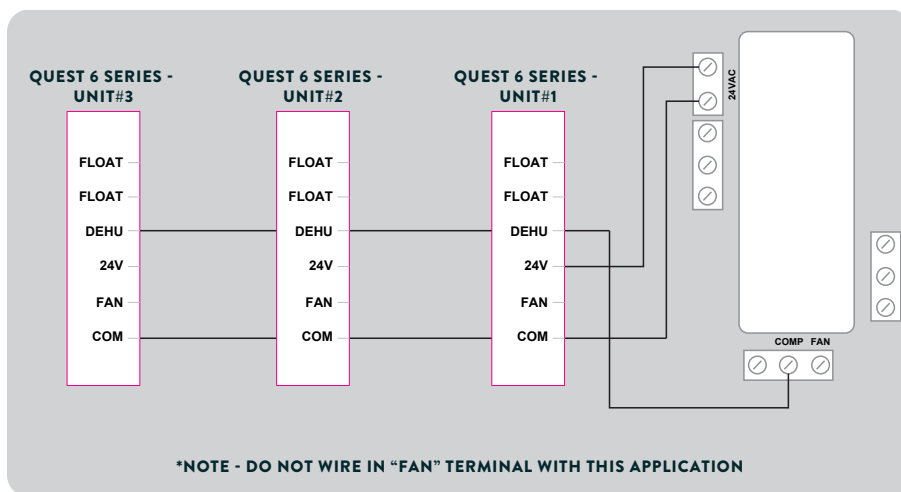

5.2 Quest 335 External Control

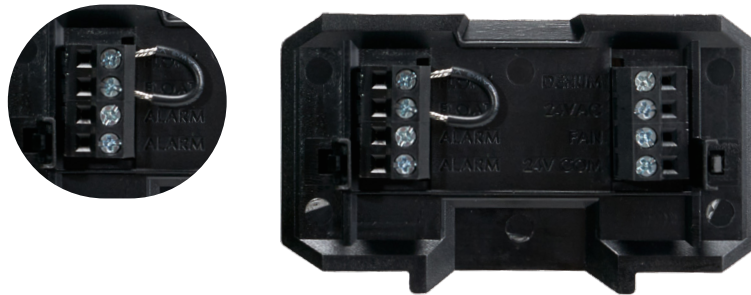

- Remove the cover from the user interface to expose the terminal block inputs & outputs.

Quest 335 Terminal Block Control Operations:

DEHUM: Dehumidification (Fan and Compressor) Control Input.

24VAC: Transformer High Side Output to External Control.

FAN: Fan Control Input.

24V COM: 24VAC Power Transformer Neutral Side Output to External Control.

FLOAT: External Low Voltage Float Switch or Water Sensor Input (Use Normally Closed Switch).

FLOAT: External Low Voltage Float Switch or Water Sensor Input (Use Normally Closed Switch).

ALARM: Normally Closed Relay Output - Indicates when dehumidifier is in an alarm state.

ALARM: Normally Closed Relay Output - Indicates when dehumidifier is in an alarm state.

Changing Max Fan Speed

- Hold the FAN button for 3 seconds, the 2-digit display will begin to flash.
- Once the display is flashing, the maximum fan speed can be adjusted 1% at a time (in the range of 20-99%).
- The new maximum fan speed can be locked by not pressing any buttons for 6 seconds or by pressing the FAN button.
- This will disable filter life compensation functionality.

6. Maintenance

⚠ WARNING! NOTE: Do not operate the unit without the filter or with a less effective filter. The heat exchange coils inside the unit could become clogged and require disassembly to clean. Filter non-compliance invalidates the product warranty.

6.1 Standard Air Filter

The Quest 335 Dehumidifier ships with a standard MERV 13 efficient pleated fabric filter. This filter should be checked every six months. Operating the unit with a dirty filter will reduce dehumidifier capacity and efficiency and may cause the compressor to cycle off and on unnecessarily on the defrost control.

To access the air filter, remove the filter access panel from the end of the Quest 335 Dehumidifier. The filter should be readily visible and can be removed by pulling it straight out of the Quest 335 Dehumidifier.

We recommend changing the filter at least every 6 months. For agriculture we recommend changing the filter with every grow cycle.

6.2 Impeller Fan Oiling

The impeller fan motor is factory lubricated for many years of normal operation, and no further oiling is required.

7. Service

⚠️ WARNING! Servicing the Quest 335 with its high pressure refrigerant system and high voltage circuitry presents a health hazard which could result in death, serious bodily injury, and/or property damage. Only qualified service people should service this unit.

7.1 Warranty

A warranty certificate has been enclosed with this unit; read it before any repair is initiated. If a warranty repair is required, call the factory first at 1-877-420-1330 for warranty claim authorization and technical assistance.

7.2 Technical Description

The Quest 335 Dehumidifier uses a refrigeration system similar to an air conditioner's to remove heat and moisture from incoming air, and add heat to the air that is discharged.

Hot, high-pressure refrigerant gas is routed from the compressor to the condenser coil. The refrigerant is cooled and condensed by giving up its heat to the air that is about to be discharged from the unit. The refrigerant liquid then passes through a filter/drier and capillary tubing which causes the refrigerant pressure and temperature to drop. It next enters the evaporator coil where it absorbs heat from the incoming air and evaporates. The evaporator operates in a flooded condition, which means that all the evaporator tubes contain liquid refrigerant during normal operation. A flooded evaporator should maintain nearly constant pressure and temperature across the entire coil, from inlet to outlet.

The compressor collects the cool refrigerant gas and compresses it to a high pressure and temperature to repeat the process.

7.3 Troubleshooting

Neither fan nor compressor running. Dehumidification is being called for. No fan call.

1. Unit unplugged or no power to outlet.
2. Humidity control set too high.
3. Loose connection in internal or control wiring.
4. Defective Compressor relay.
5. Defective control transformer.

Compressor is not running. Dehumidification is being called for. No fan call.

1. Defective compressor run capacitor.
2. Loose connection in compressor circuit.
3. Defective compressor overload.
4. Defective compressor.
5. Defrost thermostat open.

Compressor cycles on and off. Dehumidification is being called for. No fan call.

1. Low ambient temperature and/or humidity causing unit to cycle through defrost mode.
2. Defective compressor overload.
3. Defective compressor.
4. Defrost thermostat defective.
5. Dirty air filter(s) or air flow restricted.

Fan is not running. Dehumidification or fan is being called for.

1. Loose connection in fan circuit.
2. Obstruction prevents fan impeller rotation.
3. Defective fan.
4. Defective fan relay.

Low dehumidification capacity (evaporator is frosted continuously). Dehumidification is being called for

1. Defrost thermostat loose or defective.
2. Low refrigerant charge.
3. Dirty air filter(s) or air flow restricted.
4. Excessively restrictive ducting connected to unit.

No ventilation. Ventilation is being called for.

1. Loose connection in ventilation control circuit.
2. Loose connection in damper power circuit.
3. Defective fresh air damper.

Unit removes some water, but not as much as expected.

1. Air temperature and/or humidity have dropped.
2. Humidity meter and or thermometer used are out of calibration.
3. Unit has entered defrost cycle.
4. Air filter dirty.
5. Defective defrost thermostat.
6. Low refrigerant charge.
7. Air leak (eg. loose cover or ducting leaks).
8. Defective compressor.
9. Restrictive ducting.
10. Optional Condensate Pump Safety Switch open.
11. Unit is in (Lo)w fan mode

Unit Test to determine problem:

1. Detach field control wiring connections from main unit.
2. Connect the 24V and FAN from the main unit together; only the impeller fan should run. Disconnect the wires.
3. Connect the 24V and DEHU from the main unit together; the compressor and impeller fan should run.
4. If these tests work, the main unit is working properly. You should check the hygostat and field control wiring for problems next.
5. Remove the hygostat from the mounting box and detach it from the field installed control wiring. Connect the DEHU, 24V, and FAN terminals from the hygostat directly to the corresponding locations on the main unit. Leave the, FLOAT and COM terminals disconnected!
6. Turn on the fan switch; the impeller fan should run. Turn off the fan switch.
7. Turn on the humidity control; the compressor and impeller fan should run.
8. If these tests work, the problem is most likely in the field control wiring.

Filter Change Light Illuminated (Too Frequently):

1. Change filter if dirty.
2. Hold filter change button.
3. Conditions causing rapid cycling, disable filter change light.

7.4 Refrigerant Charging

If the refrigerant charge is lost due to service or a leak, a new charge must be accurately weighed in. If any of the old charge is left in the system, it must be recovered before weighing in the new charge. Refer to the unit nameplate for the correct charge weight and refrigerant type.

7.5 Impeller Fan Replacement

The motorized impeller fan is a unitary assembly consisting of the motor and impeller fan. If defective, the complete assembly must be replaced.

1. Unplug the power cord.
2. Remove the access panel, and top panel.
3. Remove the screws attaching the impeller fan support bracket to the base.
4. Disconnect the impeller fan leads inside the electric box.
5. Remove fan/bracket assembly by removing 3 screws from the bracket and inlet ring assembly.
6. Remove the defective impeller fan from the bracket and replace with it with the new impeller fan.
7. Reassemble the new impeller fan by reversing the above procedure. Note: There are two pins on the backside of the cabinet that must align with the two holes in the impeller fan support bracket.

7.6 Compressor/Capacitor Replacement

This compressor is equipped with a two terminal external overload and a run capacitor, but no start capacitor or relay (See Figure 4).

7.6A Checking Compressor Motor Circuits

Perform the following tests if the impeller fan runs but the compressor does not with the fan switch and ventilation timer OFF and the humidity control ON.

1. Unplug the unit; remove the cabinet side and the electrical connection cover on the compressor top.
2. Plug in the unit and turn the humidity control to ON. Check for volts from compressor terminal R to overload terminal 3 using an AC voltmeter. If correct voltage is present, go to step 3. If no voltage, there may be a loose connection in the compressor circuit. Test each component for continuity. See the appropriate section if a defect is suspected.
3. Unplug the unit, and then disconnect the red and yellow wires from compressor terminals R & S. Using an ohmmeter check continuity between the points listed below.
4. Compressor terminals C and S: No continuity indicates an open start winding. The compressor must be replaced. Normal start winding resistance is 3 to 7 ohms.
5. Compressor terminals C and R: No continuity indicates an open run winding. The compressor must be replaced. Normal run winding resistance is .5 to 2 ohms.
6. Compressor terminal C and overload terminal 1: No continuity indicates a defective overload lead.
7. Overload terminals 1 and 3: If there is no continuity, the overload may be tripped. Wait 10 minutes and try again. If there is still no continuity, it is defective and must be replaced.
8. Compressor terminal C and compressor case: Continuity indicates a grounded motor. The compressor must be replaced.
9. Disconnect the wires from the run capacitor. Set the ohmmeter to the Rx1 scale. The capacitor is shorted and must be replaced if continuity exists across its terminals. If there is no needle movement with the meter set on the Rx100000 scale, the capacitor is open and must be replaced.
10. Reconnect the wires to the compressor and capacitor. Plug in and turn on the unit. If the compressor fails to start, replace the run capacitor.
11. If the unit still does not start, adding a hard-start kit (relay & capacitor) will provide greater starting torque. If this doesn't work, the compressor has an internal mechanical defect and must be replaced.

7.6B Replacing a Burned Out Compressor

The refrigerant and oil mixture in a compressor is chemically very stable under normal operating conditions. However, when an electrical short occurs in the compressor motor, the resulting high temperature arc causes a portion of the refrigerant oil mixture to break down into carbonaceous sludge, a very corrosive acid, and water. These contaminants must be carefully removed otherwise even small residues will attack replacement compressor motors and cause failures.

The following procedure is effective only if the system is monitored after replacing the compressor to insure that the clean up was complete.

1. This procedure assumes that the previously listed compressor motor circuit tests revealed a shorted or open winding.
2. Remove and properly dispose of the system charge. **DO NOT** vent the refrigerant or allow it to contact your eyes or skin.
3. Remove the burned out compressor. Use rubber gloves if there is any possibility of contacting the oil or sludge.
4. To facilitate subsequent steps, determine the type of burn out that occurred. If the discharge line shows no evidence of sludge and the suction line is also clean or perhaps has some light carbon deposits, the burn out occurred while the compressor was not rotating. Contaminants are therefore largely confined to the compressor housing. A single installation of liquid and suction line filter/driers will probably clean up the system.

If sludge is evident in the discharge line, it will likely be found in the suction line. This indicates the compressor burned out while running. Sludge and acid have been pumped throughout the system. Several changes of the liquid and suction filter/driers will probably be necessary to cleanse the system.
5. Correct the system fault that caused the burn out. Consult the factory for advice.

6. Install the replacement compressor with a new capacitor and an oversized liquid line filter.
In a running burn out, install an oversized suction line filter/drier between the accumulator and compressor. Thoroughly flush the accumulator with refrigerant to remove all trapped sludge and to prevent the oil hole from becoming plugged. A standing burn out does not require a suction line filter/drier.
7. Evacuate the system with a good vacuum pump and accurate vacuum gauge. Leave the pump on the system for at least an hour.
8. Operate the system for a short period of time, monitoring the suction pressure to determine that the suction filter is not becoming plugged. Replace the suction filter/drier if pressure drop occurs. If a severe running burn out has occurred, several filter/driers may have to be replaced to remove all of the acid and moisture.

NOTE: NEVER use the compressor to evacuate the system or any part of it.

7.6C Replacing a Compressor, Non burn Out

Remove the refrigerant from the system. Replace the compressor and liquid line filter/drier. Charge the system to 50 PSIG and check for leaks. Remove the charge and weigh in the refrigerant quantity listed on the nameplate. Operate the system to verify performance.

7.7 Remote Controls

The Quest 335 Dehumidifier is controlled by devices mounted on a panel that is remote from the unit. You may or may not have the devices listed below depending on the model of the remote hygrostat you purchased. If the Quest 335 Dehumidifier fails to operate as desired, always check the settings of the controls to insure that they are correct. Check that the controls are receiving 24VAC from the Quest 335 Dehumidifier. Check the connections between the Quest 335 Dehumidifier, the hygrostat, and the field control wiring.

7.7A Humidity Control

The humidity control is an adjustable switch that closes when the relative humidity of the air in which it is located rises to the set point. It opens when the RH drops 4 to 6% below the set point. If the Quest 335 Dehumidifier does not run, try turning the humidity control Down using arrow on control pad. If it then runs, the humidity control is out of calibration or the RH is below setpoint.

The Quest 335 Dehumidifier is equipped with an automatic defrost mechanism. If the Quest 335 Dehumidifier operates in conditions that develop frost on the evaporator, it will sense the frost build-up and automatically defrost the evaporator. The Quest 335 Dehumidifier may not appear to be operating correctly during the defrost sequence, but once the defrost sequence is completed, the Quest 335 Dehumidifier will resume dehumidifying.

7.8 Defrost Thermostat

The defrost thermostat is attached to the refrigerant suction tube between the accumulator and the compressor. It will automatically shut the compressor off if the low side refrigerant temperature drops due to excessive frost formation on the evaporator coil. The impeller fan will continue to run, causing air to flow through the evaporator coil and melt the ice. When the ice has melted, the evaporator temperature will rise and the thermostat will restart the compressor.

7.9 Condensate Pump Kit

An optional condensate pump kit is available from the factory for use with the Quest 335 Dehumidifier. Condensate is automatically pumped to a remote location when the water level in the pump's reservoir rises to close the float switch.

The pump also contains a safety float switch. The white leads from this switch extend from beneath the pump cover. This switch should be installed in series with the field wire that connects the 24V from the Quest 335 Dehumidifier to the hygrostat.

If the pump fails, this switch opens the compressor control circuit and stops water production before the reservoir overflows. The Quest 335 Dehumidifier will continue to ventilate or circulate air as normal, but will not dehumidify until this switch closes.

8. Quest 335 Error Codes

1	RH Sensor Error	No valid RH reading for ~ 22 seconds Disregard for terminal control display "--"	Valid RH reading	Error Code: "E1" Circulate: 1 minute Dehumidistat: 15 minutes Dehu mode: 15 minutes Repeat Detected on power board, error communicated to UI
3	Out of Refrigerant	Evaporator doesn't get at least 5°F below ambient after being in dehumidification mode for 10 minutes or more	Lock-out for 1 hour Re-start and see if evaporator gets cold again	Error Code: "E3" Compressor off (during lock-out) Fan off (during lock-out) Goes to circulate mode
4	Normally Closed (NC) Float Switch Tripped	The FLOAT terminals on the UI are in error state. If it is open for ~ 6 seconds this alert will trigger. This should happen in all states (not just when in Terminal control)	Float inputs are open	Error code: "E4" Compressor off, fan off Use command Set: Dehu_state:off
5	Evaporator Sensor Error	Invalid reading (above 200°F or below -20°F) from the evaporator sensor for ~ 12 seconds or more	Valid evaporator sensor reading for ~ 12 seconds or more	Error code: "E5" Dehu Mode: 15 minutes Defrost Mode: 30 Minutes Repeat
6	Temperature too High	Either the evaporator or the ambient sensor is reading above 120°F	Lock-Out for 1 hour temperatures drop below threshold	Error Code: "E6" Fan off Compressor off
7	Temperature too Low	Ambient sensor reading was under 40°F when the dehumidifier was either in dehu or circulate mode: The unit will enter dehumidistat mode and stay there for at least 15 minutes	Temperature rises above threshold when the unit exits out of dehumidistat mode	Error Code: "E7" Fan off Compressor off
8	Comm Error	Communication from power board is not being received	Valid communication received from power board	Error Code: "E8" Power board continues to run unit. UI board would not be able to make changes to operation until communication is restored.

Wiring Diagram of the Quest 335 Dehumidifier

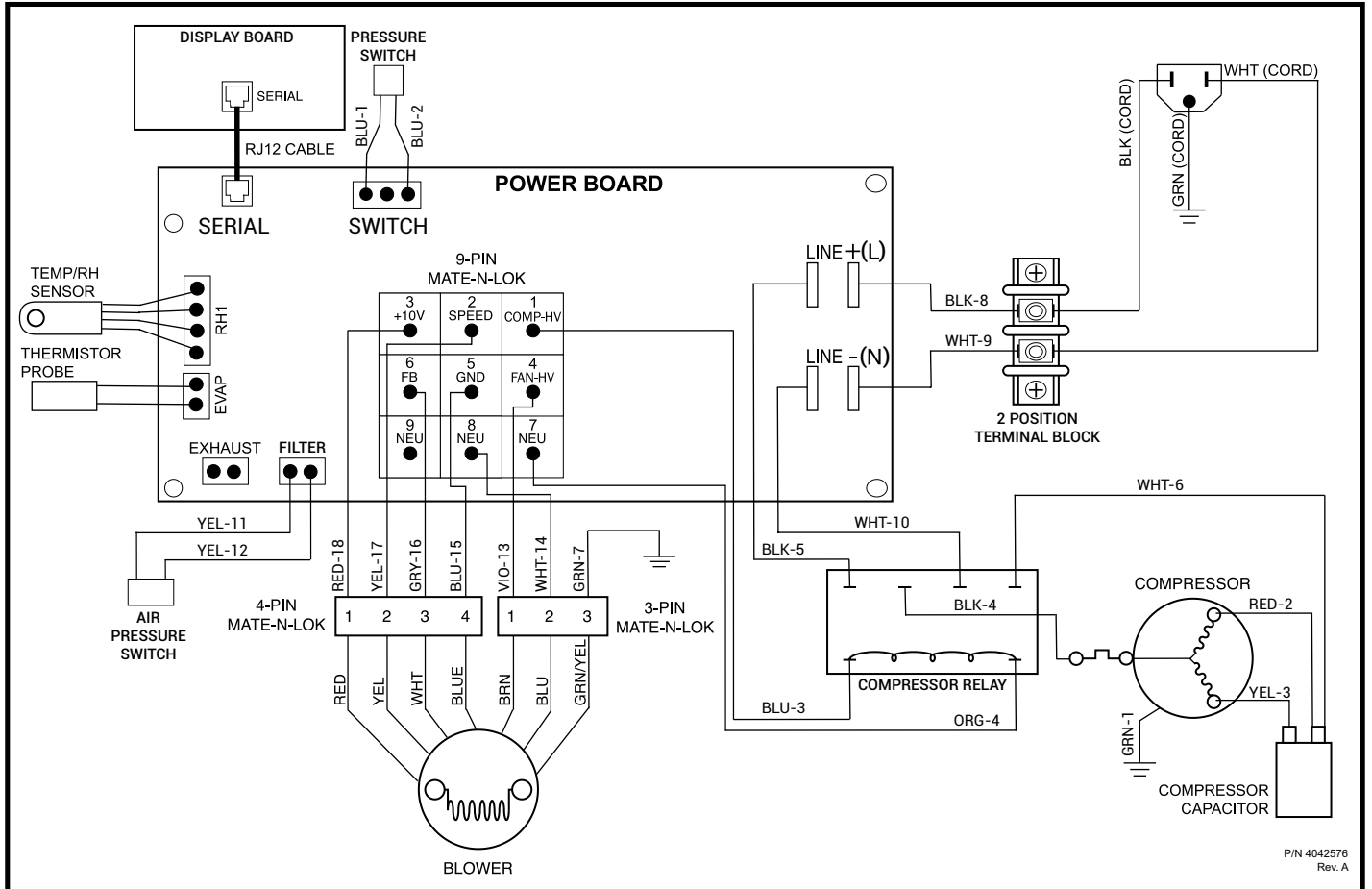

Service Parts List for Quest 335

Item	Part No	Qty	Description	Item	Part No	Qty	Description
1	4041909		UI Control Board	15	4042505		Block, Wiring
2	4042009		Cover, UI, 24VAC	16	4041892		Clip, Cord Retention
3	4042531-02		Coil Condenser	17	4042486		Switch, Pressure
4	4042061		Sensor, Temp & RH, Digital	18	4022160		Clamp, Capacitor
5	4042545-01		Filter (Not Shown)	19	4035949-03		Capacitor
6	4042529-01		Coil, Evap	20	4042483		Fan, Motorized Impeller
7	4042469		TXV	21	4036494		Cord
8	4042468		Filter, Drier				
9	4029507		Control, High Pressure				
10	4042482		CPRSR				
11	4042528		Handle, Pocket				
12	4028459		Pressure Tap				
13	4042291		Control Board				
14	4042467		Relay				

Optional Parts List

PART NO.	QTY.	DESCRIPTION	PART NO.	QTY.	DESCRIPTION
4022220	1	Pump Kit (110-120V)	4028531	1	DEH 3000R Control, Remote
4028607	1	Supply Duct Kit	4020175	1	Controller, Humidity
4028610	1	Return Duct Kit	4036668	2	Bracket, Hanging (2 Required)

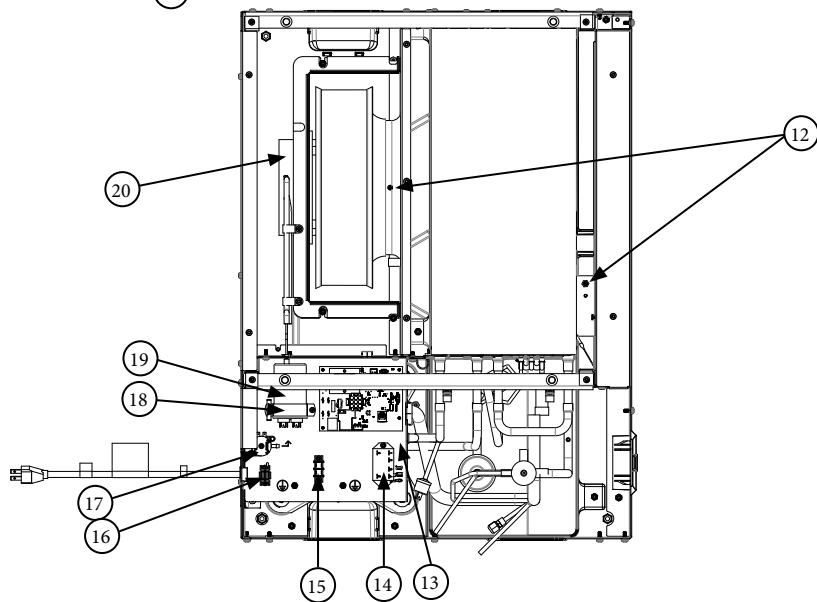
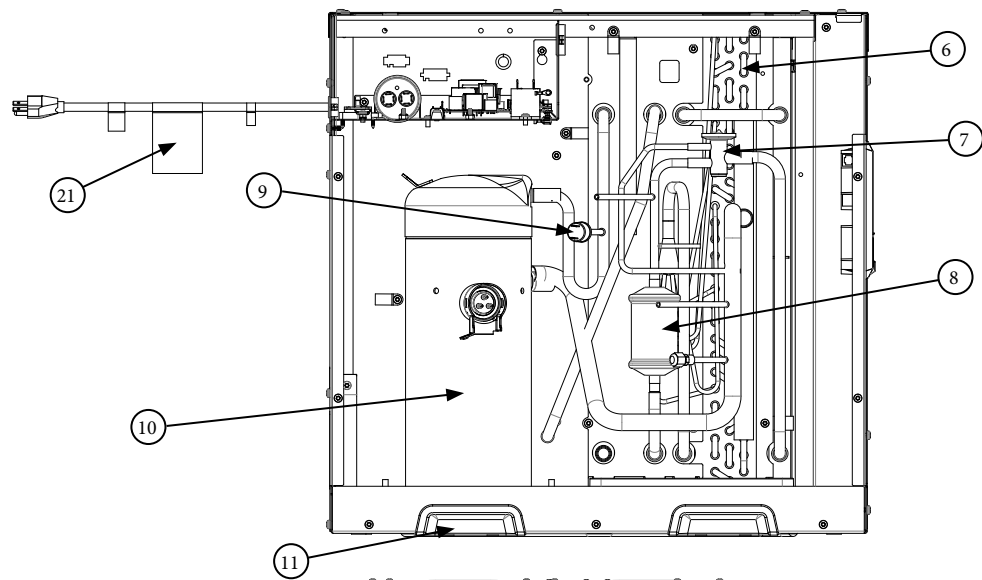
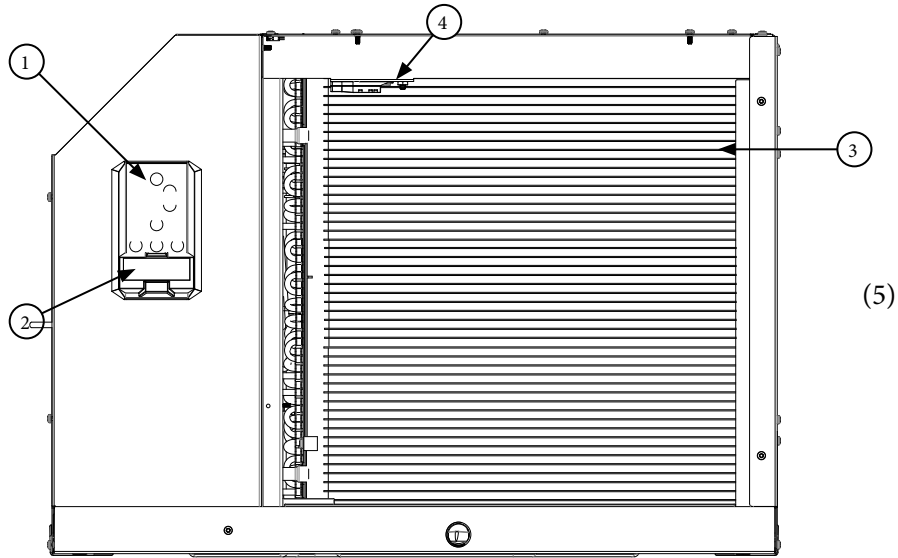

Quest 335 Dehumidifier Limited Warranty

WARRANTOR:

Therma-Stor LLC
4201 Lien Rd
Madison, WI 53704
Telephone: 1-800-533-7533

WHO IS COVERED: This warranty extends only to the original end-user of the Quest 335 Dehumidifier, and may not be assigned or transferred.

FIRST YEAR WARRANTY: Therma-Stor LLC warrants that, for one (1) year the Quest Dehumidifier will operate free from any defects in materials and workmanship, or Therma-Stor LLC will, at its option, repair or replace the defective part(s), free of any charge.

SECOND THROUGH FIFTH YEAR WARRANTY: Therma-Stor LLC further warrants that for a period of five (5) years, the condenser, evaporator, and compressor of the Quest Dehumidifier will operate free of any defects in material or workmanship, or Therma-Stor LLC, at its option, will repair or replace the defective part(s), provided that all labor and transportation charges for the part(s) shall be borne by the end-user.

END-USER RESPONSIBILITIES: Warranty service must be performed by a Servicer authorized by Therma-Stor LLC. If the end-user is unable to locate or obtain warranty service from an authorized Servicer, he should call Therma-Stor LLC at the above number and ask for the Therma-Stor LLC Service Department, which will then arrange for covered warranty service. Warranty service will be performed during normal working hours.

The End-user must present proof of purchase (lease) upon request, by use of the warranty card or other reasonable and reliable means. The end-user is responsible for normal care. This warranty does not cover any defect, malfunction, etc. resulting from misuse, abuse, lack of normal care, corrosion, freezing, tampering, modification, unauthorized or improper repair or installation, accident, acts of nature or any other cause beyond Therma-Stor LLC's reasonable control.

LIMITATIONS AND EXCLUSIONS: If any Quest Dehumidifier part is repaired or replaced, the new part shall be warranted for only the remainder of the original warranty period applicable thereto (but all warranty periods will be extended by the period of time, if any, that the Quest 335 Dehumidifier is out of service while awaiting covered warranty service).

UPON THE EXPIRATION OF THE WRITTEN WARRANTY APPLICABLE TO THE QUEST DEHUMIDIFIER OR ANY PART THEREOF, ALL OTHER WARRANTIES IMPLIED BY LAW, INCLUDING MERCHANTABILITY AND FITNESS FOR A PARTICULAR PURPOSE, SHALL ALSO EXPIRE. ALL WARRANTIES MADE BY THERMA-STOR LLC ARE SET FORTH HEREIN, AND NO CLAIM MAY BE MADE AGAINST THERMA-STOR LLC BASED ON ANY ORAL WARRANTY. IN NO EVENT SHALL THERMA-STOR LLC, IN CONNECTION WITH THE SALE, INSTALLATION, USE, REPAIR OR REPLACEMENT OF ANY QUEST DEHUMIDIFIER OR PART THEREOF BE LIABLE UNDER ANY LEGAL THEORY FOR ANY SPECIAL, INDIRECT OR CONSEQUENTIAL DAMAGES INCLUDING WITHOUT LIMITATION WATER DAMAGE (THE END-USER SHOULD TAKE PRECAUTIONS AGAINST SAME), LOST PROFITS, DELAY, OR LOSS OF USE OR DAMAGE TO ANY REAL OR PERSONAL PROPERTY.

Some states do not allow limitations on how long an implied warranty lasts, and some do not allow the exclusion or limitation of incidental or consequential damages, so one or both of these limitation may not apply to you.

LEGAL RIGHTS: This warranty gives you specific legal rights, and you may also have other rights which vary from state to state.