

QUEST 155 / 205

For complete product
information, scan here:



READ AND SAVE THESE INSTRUCTIONS

FOR A COMPLETE MANUAL, GO TO QUESTCLIMATE.COM/MANUALS, OR SCAN ABOVE.

This guide is provided to acquaint you with the dehumidifier so that installation, operation, and maintenance can proceed successfully. Ultimate satisfaction depends on the quality of installation and a thorough understanding of this equipment. The dehumidifier is built around tested engineering principles and has passed a thorough inspection for quality of workmanship and function.

ASSEMBLY & INSTALLATION

Thanks for purchasing a Quest dehumidifier. For a complete manual, visit QuestClimate.com/manuals. Please follow these steps to successfully assemble and install your new dehumidifier.

1 UNPACK BOX

⚠ **IMPORTANT!** RETAIN SHEET OF CARDBOARD UNDER MACHINE TO PREVENT SCRATCHING.

2 REGISTER WARRANTY AT THERMASTOR.COM/REGISTRATION



3 CHECK THAT YOU HAVE ALL PARTS:

- A. Dehumidifier (1)
- B. Feet (4)
- C. Drain Hose (1)
- D. Drain Adapter (1)
3/4" NPT PVC to 5/8" Hose Barb
- E. Rivnut Plugs (4)

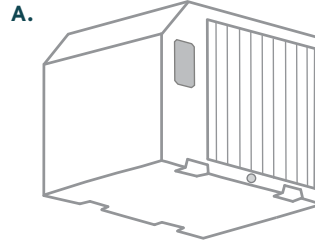

QUEST DEHUMIDIFIERS CAN RUN WITHOUT ADDITIONAL ACCESSORIES. DEPENDING ON INSTALLATION, YOU MAY REQUIRE ADDITIONAL PARTS. SEE STEP 13 FOR ADDITIONAL INFORMATION.

4 READ ALL REMAINING STEPS AND WARNINGS BEFORE CONTINUING

5 DECIDE WHERE TO PLACE UNIT IN ROOM



WARNING! Don't block airflow inlet. Outlet must be at least 12" from walls and other obstructions.



WARNING! Risk of fire due to flammable A2L refrigerant used. See manual for handling instructions and follow carefully in compliance with national regulations.

6 CHOOSE WHETHER TO PLACE ON FLOOR OR HANG DEHUMIDIFIER

A. IF YOU PLACE ON FLOOR:

Attach leveling feet. Place rivnut plugs over hang kit holes on top of unit.



B. IF YOU HANG DEHUMIDIFIER:

Using 3/8" threaded rod, attach machine to ceiling.



WARNING! Threaded rods should be engaged no less than 2" into machine. Thread jam nut at least 2" into the threaded rods, screw rods into unit until jam nuts touch the top of the unit and tighten.

Place rivnut plugs over leveling feet holes on the bottom of the unit.

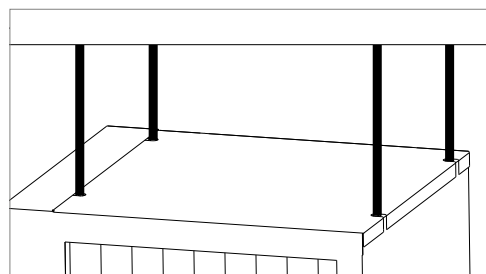

HANGING YOUR DEHUMIDIFIER

6B. (CONTINUED)

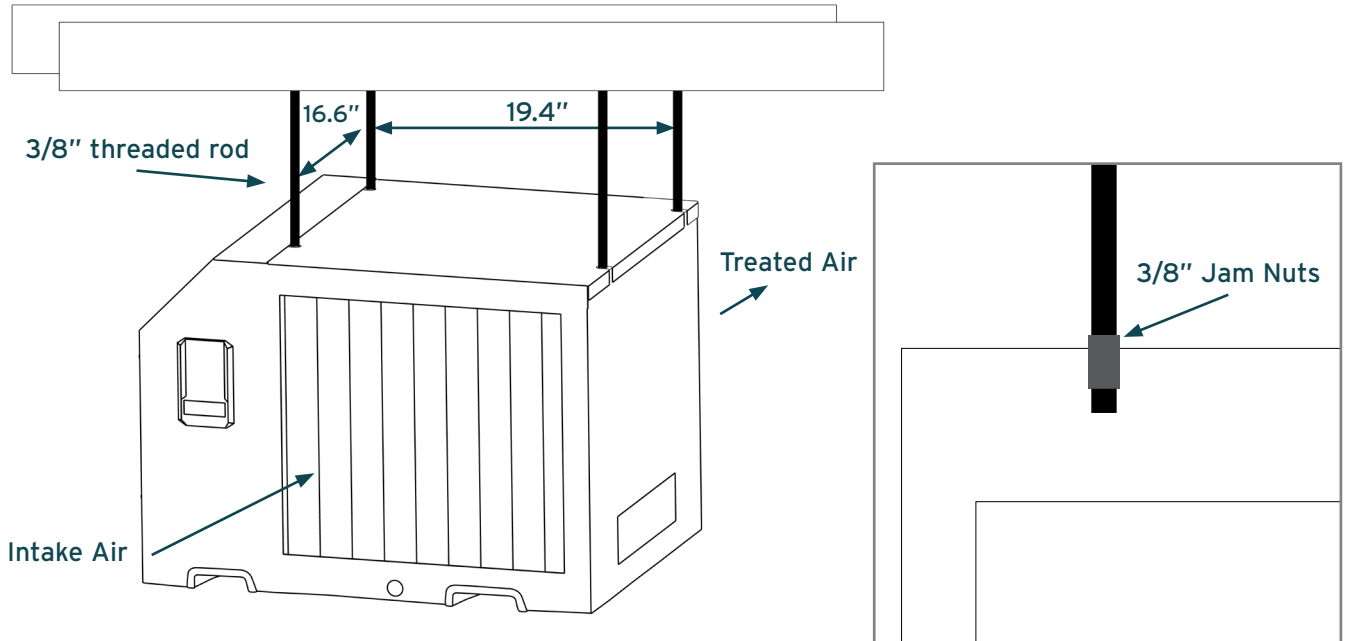

Parts Needed: 4 pieces - 3/8" threaded rod (not included)
4 pieces - 3/8" threaded jam nuts (not included)

7 INSERT DRAIN ADAPTER AND ATTACH DRAIN HOSE* TO UNIT.

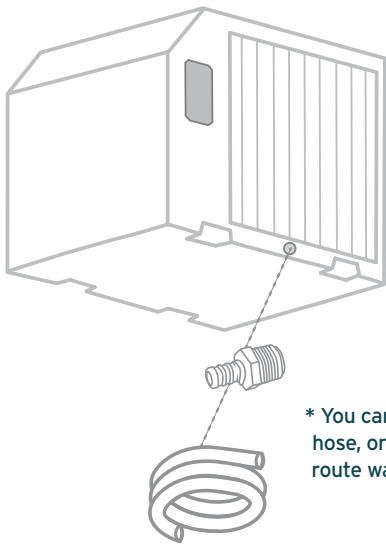

* You can use provided hose, or install PVC to route water.

8 OUTPUT TO DRAIN OR BUCKET.

A. Attach a P-Trap
(Available at most hardware stores. Or follow dimensions below to construct your own draintrap.)

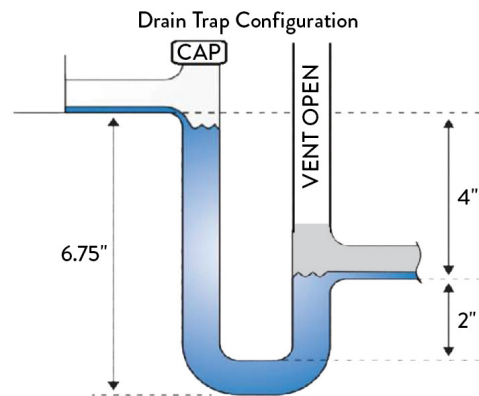

B. If you need water to travel a further distance, see Section 13 on how to order a pump kit.

C. See manual for more details.

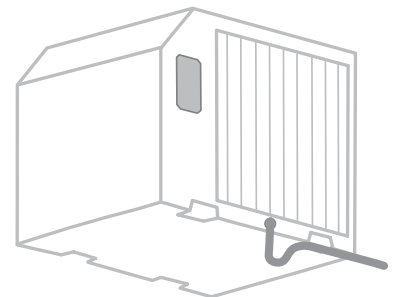

9 VERIFY WALL OUTLET IS CORRECT VOLTAGE AND AMPERAGE.

10 PLUG IN UNIT.

11 ADJUST HUMIDITY.

A. Adjust onboard setpoint to desired setting.

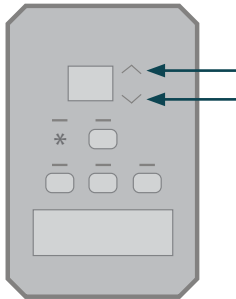

B. If you prefer external controls, see section 12, right.

WARNING! Disconnect machine from source power when making adjustments to low voltage controls.

C. To daisy chain, see manual for details.

NOTE:

The jumper wire between the two "FLOAT" terminals must stay in place unless a secondary float switch is wired in.

The jumper wire between "FAN" and "24V COM" is an extra jumper wire. If continuous fan operation is desired, you would place this jumper wire between "FAN" and "24VAC".

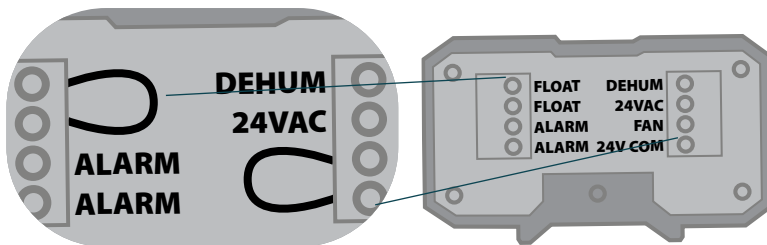

Specifications @ 80°F / 60%RH		
UNIT	QUEST 155 4046120	QUEST 205 4046110
Supply Voltage (VAC)	110-120V	110-120V
Blower @ 0.0"WG	500 CFM	575 CFM
Current Draw (Amps)	6.9A	10A
Operating Temperature	56 F - 95 F	56 F - 95 F
Air Filter (MERV-13)	Size: 18" x 18" x 2"	Size: 18" x 18" x 2"
Weight (lbs)	130	130
Capacity (Pints/Day)	155	200
Efficiency (Pints/kWh)	8.5	7.7
Power Cord	9', 115 VAC, Ground	9', 115 VAC, Ground

12 EXTERNAL CONTROL OPTIONS

4028531

QUEST DEH 3000R CONTROL WIRING DIAGRAM

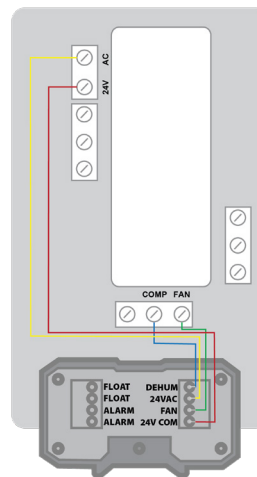

4041649

HONEYWELL HUMIDIPRO WIRING DIAGRAM

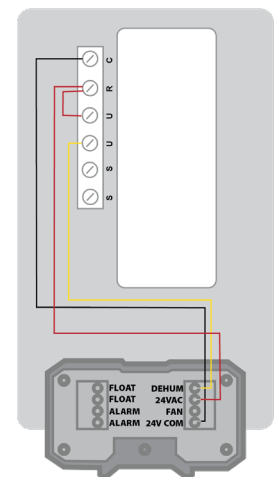

13 ACCESSORIES

To purchase additional accessories for your system, visit QuestClimate.com/Product-Category/Accessories/All-Accessories/

- A. **Replacement Filter:** Change filters every 6 months, or each grow cycle, for maximum performance.
- B. **Pump Kit:** Allows for draining and transferring water when the unit is not hard plumbed or near a drain.
- C. **Duct Kit:** Direct airflow when placing the dehumidifier outside of your room.
- D. **External Control:** Ideal for overhead installation or with duct work.



READ AND SAVE THESE INSTRUCTIONS

- » The device is designed to be installed INDOORS IN A SPACE THAT IS PROTECTED FROM RAIN AND FLOODING.
- » Install the unit with space to access the back or side panels for maintenance and service. DO NOT INSTALL UNIT WITH THE SERVICE PANELS INACCESSIBLE.
- » Avoid directing the discharge air at people, or over the water in pool areas.
- » If used near a pool, spa or water; be certain there is NO chance the unit could fall into the water, be splashed and that it is plugged into an outlet that is a GROUND FAULT INTERRUPT protected circuit.
- » DO NOT use the device as a bench or table.
- » DO NOT place the device directly on structural members. Provide vibration isolation in order to minimize operational vibration and/or noise.
- » A drain pan MUST be placed under the unit if installed above a living area or above an area where water leakage could cause damage.
- » Never operate a unit with a damaged power cord. If the power cord is damaged it must be replaced by the manufacturer, its service agent, or similarly qualified person in order to avoid a hazard.
- » Make all electrical connections in accordance with the current edition of the NEC ANSI/NFPA 70 and any national and local codes or ordinances that may apply.
- » Do not obstruct the air intake and exhaust. Maintain a 3 ft (1 m) clearance around the air intake and exhaust.
- » This appliance is not intended for use by persons (including children) with reduced physical, sensory or mental capabilities, or lack of experience and knowledge, unless they have been given supervision or instruction concerning use of the appliance by a person responsible for their safety. Children should be supervised to ensure that they do not play with the appliance.

 **WARNING** Do not use means to accelerate the defrosting process or to clean, other than those recommended by the manufacturer.

The appliance shall be stored in a room without continuously operating ignition sources (for example: open flames, an operating gas appliance, or an operating electric heater.

Do not pierce or burn. Be aware that refrigerants may not contain an odor.

LIMITED WARRANTY

WARRANTOR:

Therma-Stor LLC
4201 Lien Rd
Madison, WI 53704
Telephone: 1-877-420-1330



WHO IS COVERED: This warranty extends only to the original end-user of the Quest 155 or Quest 205 dehumidifier, and may not be assigned or transferred.

FIRST YEAR WARRANTY: Therma-Stor LLC warrants that for one (1) year the Quest 155/205 dehumidifier will operate free from any defects in materials and workmanship, or Therma-Stor LLC will, at its option, repair or replace the defective part(s), free of any charge.

SECOND THROUGH FIFTH YEAR WARRANTY: Therma-Stor LLC further warrants that for a period of five (5) years, the condenser, evaporator and compressor of the Quest dehumidifier will operate free of any defects in material or workmanship, or Therma-Stor LLC, at its option, will repair or replace the defective part(s), provided that all labor and transportation charges for the part(s) shall be borne by the end-user.

END-USER RESPONSIBILITIES: Warranty service must be performed by a Servicer authorized by Therma-Stor LLC. If the end-user is unable to locate or obtain warranty service from an authorized Servicer, he should call Therma-Stor LLC at the above number and ask for the Therma-Stor LLC Service Department, which will then arrange for covered warranty service. Warranty service will be performed during normal working hours. The end-user must present proof of purchase (lease) upon request, by use of the warranty card or other reasonable and reliable means. The end-user is responsible for normal care. This warranty does not cover any defect, malfunction, etc., resulting from misuse, abuse, lack of normal care, corrosion, freezing, tampering, modification, unauthorized or improper repair or installation, accident, acts of nature or any other cause beyond Therma-Stor LLC's reasonable control.

LIMITATIONS AND EXCLUSIONS: If any Quest 155/205 dehumidifier part is repaired or replaced, the new part shall be warranted for only the remainder of the original warranty period applicable thereto (but all warranty periods will be extended by the period of time, if any, that the Quest dehumidifier is out of service while awaiting covered warranty service).

UPON THE EXPIRATION OF THE WRITTEN WARRANTY APPLICABLE TO THE QUEST DEHUMIDIFIER OR ANY PART THEREOF, ALL OTHER WARRANTIES IMPLIED BY LAW, INCLUDING MERCHANTABILITY AND FITNESS FOR A PARTICULAR PURPOSE, SHALL ALSO EXPIRE. ALL WARRANTIES MADE BY THERMA-STOR LLC ARE SET FORTH HEREIN, AND NO CLAIM MAY BE MADE AGAINST THERMA-STOR LLC BASED ON ANY ORAL WARRANTY. IN NO EVENT SHALL THERMA-STOR LLC, IN CONNECTION WITH THE SALE, INSTALLATION, USE, REPAIR OR REPLACEMENT OF ANY QUEST DEHUMIDIFIER OR PART THEREOF BE LIABLE UNDER ANY LEGAL THEORY FOR ANY SPECIAL, INDIRECT OR CONSEQUENTIAL DAMAGES INCLUDING WITHOUT LIMITATION WATER DAMAGE (THE END-USER SHOULD TAKE PRECAUTIONS AGAINST SAME), LOST PROFITS, DELAY OR LOSS OF USE OR DAMAGE TO ANY REAL OR PERSONAL PROPERTY. SOME STATES DO NOT ALLOW LIMITATIONS ON HOW LONG AN IMPLIED WARRANTY LASTS, AND SOME DO NOT ALLOW THE EXCLUSION OR LIMITATION OF INCIDENTAL OR CONSEQUENTIAL DAMAGES, SO ONE OR BOTH OF THESE LIMITATIONS MAY NOT APPLY TO YOU.

LEGAL RIGHTS: This warranty gives you specific legal rights, and you may also have other rights which vary from state to state.

SERIAL
NUMBER



PART
NUMBER



PLACE LABEL HERE



REGISTER YOUR NEW DEHUMIDIFIER

using the serial number
and part number at
[thermastor.com/
registration](https://thermastor.com/registration)
or scan code above

FOR INTERNAL USE ONLY

